

<b>Engine</b>	Yanmar 3TNV80F-SSLY, EU Stage V
<b>Net Power</b>	18 hp (13.4 kW)
<b>Operating Weight</b>	Canopy 1,800 kg (3,968 lb) Cab 1,900 kg (4,189 lb)
<b>Bucket Capacity</b>	0.045 m <sup>3</sup> (0.059 yd <sup>3</sup> )

# 9018F

EXCAVATOR



**TOUGH WORLD. TOUGH EQUIPMENT.**

# OUR NEW F-SERIES EXCAVATORS. THE BEST – GETS EVEN BETTER.

We've taken the best from our E-Series machines, combined that with extensive R&D and customer insight to deliver the F-Series, a new range of state-of-the-art excavators designed with the operator at the heart.

Tough and intelligent, the F-Series shares our Red Dot award-winning design DNA and is developed to let the operator do more in safety and comfort.

## 9018F. COMPACT IN SIZE – BIG ON PERFORMANCE

No two job sites are the same. Utilities, foundation work, landscaping, indoor/outdoor demolition and construction projects all present unique challenges to the operator. Space is often limited, visibility compromised, the work is tough, whilst time is invariably short. Our challenge was to create something different. Big machine performance – in a compact design.

## NOT JUST ANOTHER COMPACT MACHINE

Listening to operators, our design brief was clear. Make it compact, light and easy to transport. Make it tough, comfortable, powerful and simple to use. Make it quick to service and maintain.

### OUR NEW 9018F DELIVERS ON 4 ESSENTIAL NEEDS:

1



**EASY TO  
TRANSPORT**

2



**SIMPLE  
TO USE**

3



**QUICK TO  
MAINTAIN**

4



**LOW TOTAL COST  
OF OWNERSHIP**



With the new 9018F, we've created something different. An exceptionally performing compact machine which gives operators everything they want – without compromise.



## TOUGH FACTS

### AWARD WINNING DESIGN

Our UK-based design team has invested thousands of man hours to really understand how our machines are used every day. This insight shapes our innovative approach to product design. Our design team recently won a prestigious Red Dot Award for our D-Series Grader and our New F-Series shares this award-winning design DNA.

### TOUGH RESEARCH AND TESTING

Finding tougher, smarter, safer and more cost-effective ways of working matters to you. It matters to us too. Our new Global Research & Development Centre is a great example of this customer focused approach. We've established an international team of industry experts, backed up with the latest world-class technology, all focused on delivering greater value to you.

### TOUGH QUALITY STANDARDS

When it comes to quality, we let our actions to speak for themselves. We follow a rigorous Six Sigma methodology and consistently achieve ISO 9001 standards.

# DESIGN IN ACTION

Take a walk around the new 9018F and you will see the difference. It has big excavator performance – in smart, compact body.

## DESIGNED TO LET YOU SEE WHAT'S GOING ON

LiuGong is creating a reputation for excellent visibility and the new 9018F is no exception. With high-visibility cabs, protected by ROPS & TOPS, the new 9018F really lets you see what is going on. Performance and safety are high on our agenda, but our cabs set a new level of comfort too. Operators demand more and we've delivered with ergonomic design and unmatched comfort.

## SAVE MORE WITH THE OPTIONAL AUTO-IDLE SPEED FUNCTION

For greater efficiency, this intelligent feature decreases and increases the engine speed as required achieving higher levels of fuel efficiency without compromising on performance.

## ONE MACHINE – MULTIPLE POSSIBILITIES

High flow auxiliary lines are fitted as standard with an optional rotation circuit available. With an additional counterweight, the machine can be fitted with heavier work tools to match multiple job site challenges. A range of specially designed buckets can also be chosen depending on task in hand.

## NO SPACE? NO PROBLEM!

When space is tight, the neat compact design with short tail swing gets you to work. Agile and ergonomic Boom Swing control allows the new 9018F working access to the smallest spaces with a 72-degree swing to the left and 52-degrees to the right.

## EASY TO TRANSPORT

Lightweight, compact design with retractable undercarriage makes this machine simple to move from one place to another, no matter how narrow the access. With excellent visibility and precision control, this machine can get off the trailer and onto the site fast and safely every time.





## PUTTING YOU IN CONTROL

Control is everything. Load sensing hydraulics deliver precise and smooth operation for excellent grading performance. The electro-proportional auxiliary line enables easy and accurate control of the attachments. The new dozer blade geometry allows the bucket and the blade to work in harmony to speedily sweep away materials.

## AT YOUR SERVICE

For speed and simplicity, the engine covers, fuelling and maintenance access points have all been designed to make daily checks and maintenance pain free.

## GETS YOU STARTED

No matter how cold the weather, pilot oil is pre-heated during start up, making the machine ready to go in seconds.

## INTELLIGENT POWER

The fuel efficient, low noise and low emission Stage V certified Yanmar 3TNV80F-SSLY engine gives the operator the power to perform. With perfectly matched hydraulics for greater efficiency, operators can expect to reduce fuel consumption by up to 10% compared with the industry average.

## EASY DOES IT

Fully opening side covers give easy access to air filter, oil filter, fuel prefilter, dipstick, hydraulic tank and oil fill cap, not to mention the engine, main pump and radiator.

## KEEPING YOU ON TRACK

Steel tracks for harsh conditions, rubber tracks for urban paved areas; the new 9018F gives you the possibility to work anywhere. Thanks to a simple one-touch button, the automatic retractable undercarriage with a telescopic range of between 980 – 1290mm gets you in and out of the tightest spaces with ease.

---

## TOUGH JUDGES

Operators are tough judges. They know what they like and what they don't. We've talked, we've listened and we've delivered a no-nonsense excavator that will do everything the operator wants and needs it to do. Job done? Judge for yourself.

## TOUGH EQUIPMENT

**40,000 Excavators** currently in the field.  
**Over 1/2 BILLION** productive hours worked.

---



# JOBSITE UPTIME AND SUPPORT

Compact size with big performance might convince you to buy your first new 9018F, but it's uptime and support and total cost of ownership which will keep you coming back to buy more. Having confidence in the machine's back up and support network is a vital part of the purchasing decision. How do we measure up?

## FAST RESPONDING GLOBAL NETWORK

We have an extensive dealer network of over 300 dealers in more than 100 countries.

All supported by 13 regional subsidiaries and 12 global parts centers offering expert training, parts and service support.



**WE ARE LIUGONG. WORKING HARD TO KEEP OUR GLOBAL CUSTOMERS EARNING**

- 9,500+ Employees
- 20 Factories
- 13 Global offices
- 300+ Dealers
- 1,000+ R&D engineers
- 5 R&D facilities
- 12 Regional parts depots
- Over 60 Years' experience

## WHERE YOU NEED US WHEN YOU NEED US

Reliability is built into our machines but all machines have some planned downtime. Our aim is to reduce even planned down time to the minimum by getting it right.

Technician training and parts availability are also high on our agenda, as is keeping you

informed on service and maintenance work and providing clear and accurate estimates, invoices and communication.

These may be small things, but customer feedback tells us that these basics really matter – so we aim to get them right.

## MAINTENANCE AND SUPPORT PACKAGES

From genuine LiuGong parts, to full repair and maintenance contracts, LiuGong has the flexibility to offer the level of support and response to suit your business and applications. Whatever level of support you choose you can be confident that it is backed up by LiuGong's service promise.



**Right parts.  
Right price.  
Right service.**

**Above all,  
we get it right  
the first time.**

# 1<sup>st</sup>



## LIUGONG SERVICE PROMISE



Highly trained technicians  
utilizing the latest  
diagnostic equipment



15,000+ Genuine LiuGong  
parts available within 24hrs  
from our European Parts  
Distribution Center



Multi-lingual service helpline  
and online support



Transparent estimates  
and invoicing



Clear communications through  
electronic parts catalogue



# TOTAL COST OF OWNERSHIP

Easy to transport, simple to use and quick to maintain, the new 9018F appears to have it all. But ultimately, the machines earning potential, its overall life cost and its trade-in value really matter too.

When it comes to total cost of ownership LiuGong has a strong story to tell.

## PROFESSIONAL ADVICE

We are committed to reducing your total cost of ownership and increasing your profits. As part of this, LiuGong's experts will provide targeted advice on everything, from choosing the right machine for your needs to maximizing its efficiency on site.

## MACHINE AVAILABILITY

Our machines deliver everything you need and nothing you don't. They are expertly engineered NOT over engineered. As a result of having an extensive manufacturing operation right in the heart of Europe, we can offer significantly shorter lead times on

a range of models, compared with some manufacturers. In fact, we can deliver selected machines in as little as 4 weeks.

The faster you can get a machine – the faster you can get working and earning.

Our aim is to get you on to the job site fast.

## TICKET PRICE

At LiuGong, our aim is to provide you with real, measurable value by giving you everything you need and nothing you don't. We choose high quality, proven components and parts from world-renowned brands and suppliers.

These proven components, combined with LiuGong design and manufacturing quality, result in a high quality, competitive machine that is totally fit for purpose.

## RESIDUAL VALUE

With the combination of LiuGong design and manufacturing excellence, world class components and comprehensive uptime support, our quality holds its value.







## IT ALL ADDS UP

With the new 9018F we've risen to the challenge and given you everything you need and nothing you don't.

It's an excavator which can handle any job, anywhere, backed up by LiuGong's service promise and designed to perform on the job site and on the balance sheet. Add up the benefits and you'll see that the new 9018F represents the formula for success.



**EASY TO TRANSPORT**

+

**SIMPLE TO USE**

+

**QUICK TO MAINTAIN**

+

**TOTAL COST  
OF OWNERSHIP**

---

**CUSTOMER SATISFACTION**

---

# SPECIFICATIONS

<b>Operating weight</b>	Canopy 1,800 kg (3,968 lbs)
	Cab 1,900 kg (4,189 lbs)

Operating weight includes coolant, lubricants, full fuel tank, cab, standard Shoes, boom, arm, bucket and operator 75 kg (165 lbs).

<b>Bucket capacity</b>	0.045 m <sup>3</sup> (0.059 yd <sup>3</sup> )
------------------------	---

## ENGINE

### Description

Yanmar EU Stage V, 3-cylinder straight four strokes, indirect injection.

Emission rating	EPA Tier 4F / EU Stage V
Engine manufacturer	Yanmar
Engine model	3TNV80F-SSLY
Aspiration	Natural
Charged air cooling	Aftercooler
Cooling fan drive	Direct
Displacement	1.267 L (0.33 gal)
Rated speed	2,200 rpm
Engine output - net	13.4 kW (18 hp)
Maximum torque	67.4 Nm (49.71 lb-ft) @1,600 rpm
Bore × Stroke	80 × 84 mm (3.1" × 3.3")

## UNDERCARRIAGE

Track shoe each side	37 (1.5" metal) / 70 (2.8" rubber)
Link pitch	90 mm (3.5" metal) / 48 mm (1.9" rubber)
Shoe width, triple grouser	230 mm (9")
Bottom rollers each side	3
Top rollers each side	-

## SWING SYSTEM

### Description

Planetary gear reduction driven by high torque axial piston motor, with oil disk brake. Swing parking brake resets within five seconds after swing pilot controls return to neutral

Swing speed	9.5 rpm
Swing torque	2,119 N·m (1,563 lbf-ft)

## HYDRAULIC SYSTEM

### Main pump

Type	Load-sensing variable pump
Maximum flow	55 L/min (15 gal/min)

### Relief valve setting

Implement	21 MPa (3,046 psi)
Travel circuit	21 MPa (3,046 psi)
Slew circuit	13.2 MPa (1,915 psi)
Pilot circuit	3.5-3.9 MPa (508-566 psi)

### Hydraulic cylinders

Boom Cylinder – Bore × Stroke	Ø60 × 462 mm (2.4"×1' 6")
Arm Cylinder – Bore × Stroke	Ø60 × 365 mm (2.4"×1' 2")
Bucket Cylinder – Bore × Stroke	Ø60 × 295 mm (2.4"×11")

## ELECTRIC SYSTEM

System Voltage	12 V
Batteries	12 V
Alternator	12 V - 40 A
Start motor	12 V - 1.4 kW (24 V - 1.9 hp)

## SERVICE CAPACITIES

Fuel tank	28 L (7.4 gal)
Engine oil	4.4 L (1.2 gal)
Cooling system	3.3 L (0.9 gal)
Hydraulic reservoir	24 L (6.3 gal)
Hydraulic system total	-

## SOUND PERFORMANCE

Interior Sound Power Level (ISO 6396)	78 dB(A)
Exterior Sound Power Level (ISO 6395)	90 dB(A)

## DRIVE AND BRAKES

### Description

Steering controlled by two hand levers with pedals.

Max. travel speed	High: 4.5 km/h (2.8 mph)
	Low: 2.7 km/h (1.7 mph)
Gradeability	30°/58%
Max. drawbar pull	16 kN (3,597 lbf)

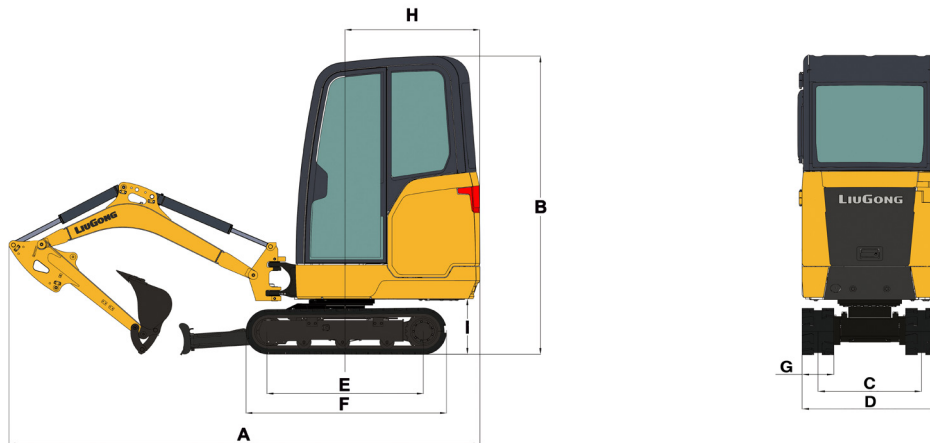

## DIMENSIONS

Boom	1,685 mm (5'6")	
Arm Options	1,070 mm (3'6")	1,210 mm (4')
A Shipping Length	3,707 mm (12'2")	3,668 mm (12')
B Shipping Height – Top of Boom	2,350 mm (7'9")	
C Track Gauge	750 / 1,060 mm (2'6" / 3'6")	
D Undercarriage Width	980 / 1,290 mm (3'3" / 4'3")	
E Length to Center of Rollers	1,230 mm (4')	
F Track Length	1,580 mm (5'2")	
G Track Shoe Width	230 mm (9")	
H Tail Swing Radius	1,070 mm (3'6")	
I Counterweight Ground Clearance	435 mm (1'5")	
Overall Height of Cab	1,635 / 1,670 mm (cab / canopy) (5'4" / 5'6")	
Min. Ground Clearance	100 mm (4")	
Overall Width of Upper Structure	980 mm (3'3")	
Distance Between The Working Device And Swing Center--Right	419 mm (1'4")	
Distance Between The Working Device And Swing Center--Left	558 mm (1'10")	
Maximum Boom Swing Angle to the Right	58°	
Maximum Boom Swing Angle to the Left	72°	

## BOOM DIMENSIONS

Boom	1,685 mm (5'6")
Length	1,767 mm (5'10")
Height	615 mm (2')
Width	246 mm (10")
Weight	87.5 kg (193 lbs)

Cylinder, piping and pin included. Boom cylinder pin excluded.

## ARM DIMENSIONS

Arm	1,070 mm (3'6")	1,210 mm (4')
Length	1,305 mm (4'3")	1,450 mm (4'9")
Height	282 mm (11")	248 mm (10")
Width	113 mm (4")	113 mm (4")
Weight	50 kg (110 lbs)	52 kg (115 lbs)

Cylinder, linkage and pin included.

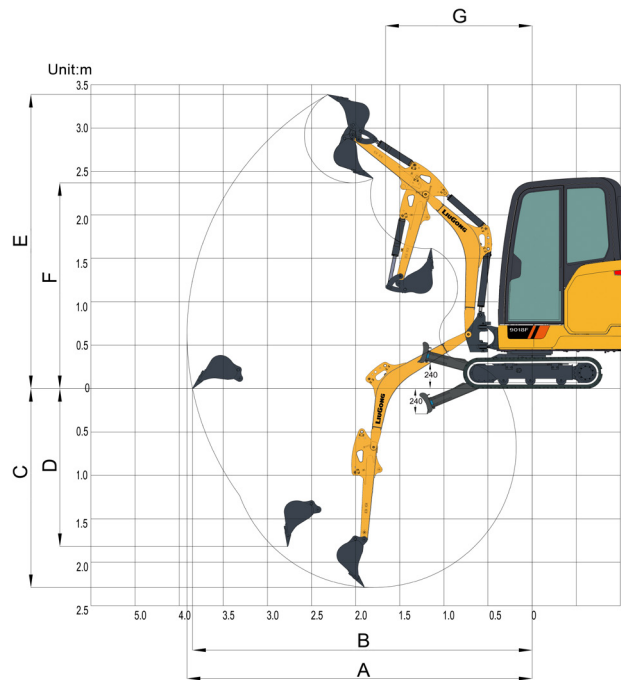

**WORKING RANGE**

Boom Length	1,685 mm (5'6")	
Arm Options	1,070 mm (3'6")	1,210 mm (4')
A. Max. Digging Reach	3,910 mm (12'10")	4,040 mm (13'3")
B. Max. Digging Reach on Ground	3,850 mm (12'8")	3,980 mm (13'1")
C. Max. Digging Depth	2,290 mm (7'6")	2,430 mm (8')
D. Max. Vertical Wall Digging Depth	1,820 mm (6')	1,950 mm (6'5")
E. Max. Cutting Height	3,385 mm (11'1")	3,475 mm (11'5")
F. Max. Dumping Height	2,370 mm (7'9")	2,460 mm (8'1")
G. Min. Front Swing Radius	1,660 mm (5'5")	1,700 mm (5'7")
Lift above Ground	240 mm (9")	240 mm (9")
Blade up	240 mm (9")	240 mm (9")
Blade down	16 kN (3,597 lbf)	16 kN (3,597 lbf)
Arm Digging Force (ISO)	9 kN (2,023 lbf)	8 kN (1,798 lbf)
Bucket Capacity	0.045 m <sup>3</sup> (0.059 yd <sup>3</sup> )	0.045 m <sup>3</sup> (0.059 yd <sup>3</sup> )
Bucket Tip Radius	548 mm (1'10")	548 mm (1'10")

**MACHINE WEIGHTS & GROUND PRESSURE**

Shoe width	Cab/Canopy	Shoe type	Operating weight	Ground pressure	Overall width
			1,685 mm (5'6"), 1,070 mm (3'6") arm, 0.045 m <sup>3</sup> (0.059 yd <sup>3</sup> ) bucket, 70 kg (154 lb) counterweight		
230 mm (9')	Cab	Rubber	1,900 kg (4,189 lb)	30.5 kPa (4.4 psi)	1,290 mm (4'3")
		Metal	1,900 kg (4,189 lb)	30.5 kPa (4.4 psi)	1,290 mm (4'3")
	Canopy	Rubber	1,800 kg (3,968 lb)	28.9 kPa (4.2 psi)	1,290 mm (4'3")

Lifting capacity at the arm end without bucket.  
 For lifting capacity including bucket, weight of the bucket or the bucket with quick coupler must be deducted from the lifting capacities.  
 Lifting capacities are based on the machine standing on a firm, uniform supporting surface.



Rating over-front (Cf)



Rating over-side (Cs)

1. Do not attempt to lift or hold any load that is greater than these rated values at their specified load radius and height. Weight of all accessories must be deducted from the above lifting capacities.
2. The rated loads are in compliance with ISO 10567 Hydraulic Excavator Lift Capacity Rating Standard. They do not exceed 87% of hydraulic lifting capacity or 75% tipping load.
3. Ratings at bucket lift hook.

4. Lifting capacities are based on machine standing on level, firm and uniform ground.
5. \*Indicates the load is limited by hydraulic capacity rather than tipping capacity.
6. Operator should be fully acquainted with the Operator's and Maintenance Instructions before operating this machine and rules for the safe operation of equipment should be adhered to at all times.

## LIFTING CAPACITY (METRIC)

### 9018F with 230 mm Shoes, 1,685 mm Boom, 1,070 mm Arm

A: Load radius  
 B: Load point height  
 C: Lifting capacity rating  
 Cf: Rating loads over front  
 Cs: Rating loads over side or 360°

### Conditions

Boom length: 1,685 mm  
 Arm length: 1,070 mm  
 Shoes: 230 mm  
 Bucket: None  
 Unit: kg

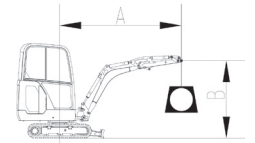

#### A (Blade Up)

B (m)		1.5m		2m		2.5m		3m		MAX REACH		A (m)
		Cf	Cs	Cf	Cs	Cf	Cs	Cf	Cs	Cf	Cs	
2.5	kg	-	-	-	-	352	272	-	-	334	259	2.6
2.0	kg	-	-	-	-	*350	274	-	-	268	207	3.0
1.5	kg	-	-	443	*360	348	269	264	204	238	183	3.2
1.0	kg	-	-	473	359	339	260	260	200	222	171	3.3
0.5	kg	-	-	452	340	329	251	255	195	218	166	3.4
Ground Level	kg	686	496	439	328	321	243	251	191	222	169	3.3
-0.5	kg	686	496	435	324	317	240	249	189	238	181	3.1
-1.0	kg	691	500	436	325	318	240	-	-	273	208	2.8
-1.5	kg	702	510	443	331	-	-	-	-	365	276	2.3

#### A (Blade Down)

B (m)		1.5m		2m		2.5m		3m		MAX REACH		A
		Cf	Cs	Cf	Cs	Cf	Cs	Cf	Cs	Cf	Cs	
2.5	kg	-	-	-	-	*375	272	-	-	*396	259	2.6
2.0	kg	-	-	-	-	*350	274	-	-	*406	207	3.0
1.5	kg	-	-	*360	*360	*409	269	*410	204	*403	183	3.2
1.0	kg	-	-	*611	359	*500	260	*435	200	*395	171	3.3
0.5	kg	-	-	*787	340	*569	251	*453	195	*386	166	3.4
Ground Level	kg	*731	496	*813	328	*583	243	*446	191	*380	169	3.3
-0.5	kg		496	*752	324	*546	240	*405	189	*374	181	3.1
-1.0	kg		500	*648	325	*467	240	-	-	*374	208	2.8

Lifting capacity at the arm end without bucket.  
 For lifting capacity including bucket, weight of the bucket or the bucket with quick coupler must be deducted from the lifting capacities.  
 Lifting capacities are based on the machine standing on a firm, uniform supporting surface.



Rating over-front (Cf)



Rating over-side (Cs)

1. Do not attempt to lift or hold any load that is greater than these rated values at their specified load radius and height. Weight of all accessories must be deducted from the above lifting capacities.
2. The rated loads are in compliance with ISO 10567 Hydraulic Excavator Lift Capacity Rating Standard. They do not exceed 87% of hydraulic lifting capacity or 75% tipping load.
3. Ratings at bucket lift hook.

4. Lifting capacities are based on machine standing on level, firm and uniform ground.
5. \*Indicates the load is limited by hydraulic capacity rather than tipping capacity.
6. Operator should be fully acquainted with the Operator's and Maintenance Instructions before operating this machine and rules for the safe operation of equipment should be adhered to at all times.

## LIFTING CAPACITY (IMPERIAL)

### 9018F with 9" Shoes, 5'6" Boom, 3'6" Arm

A: Load radius  
 B: Load point height  
 C: Lifting capacity rating  
 Cf: Rating loads over front  
 Cs: Rating loads over side or 360°

### Conditions

Boom length: 5'6"  
 Arm length: 3'6"  
 Shoes: 9"  
 Bucket: None  
 Unit: lbs

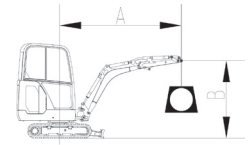

### A (Blade Up)

B (ft)		5 ft		7 ft		8 ft		10 ft		MAX REACH		A (ft)
		Cf	Cs	Cf	Cs	Cf	Cs	Cf	Cs	Cf	Cs	
8	lbs	-	-	-	-	777	600	-	-	737	572	8.5
7	lbs	-	-	-	-	*773	605	-	-	592	457	9.8
5	lbs	-	-	978	*795	768	594	583	450	525	404	10.5
3	lbs	-	-	1,044	792	748	574	574	442	490	377	10.9
2	lbs	-	-	998	751	726	554	563	430	481	366	11.0
Ground Level	lbs	1,514	1,095	969	724	709	536	554	422	490	373	10.8
-2	lbs	1,514	1,095	960	715	700	530	550	417	525	400	10.2
-3	lbs	1,525	1,104	962	717	702	530	-	-	603	459	9.2
-5	lbs	1,550	1,126	978	731	-	-	-	-	806	609	7.5

### A (Blade down)

B (ft)		5 ft		7 ft		8 ft		10 ft		MAX REACH		A (ft)
		Cf	Cs	Cf	Cs	Cf	Cs	Cf	Cs	Cf	Cs	
8	lbs	-	-	-	-	*828	600	-	-	*874	572	8.5
7	lbs	-	-	-	-	*773	605	-	-	*896	457	9.8
5	lbs	-	-	*795	*795	*903	594	*905	450	*890	404	10.5
3	lbs	-	-	*1,349	792	*1,104	574	*960	442	*872	377	10.9
2	lbs	-	-	*1,737	751	*1,256	554	*1,000	430	*852	366	11.0
Ground Level	lbs	*1,614	1,095	*1,795	724	*1,287	536	*985	422	*839	373	10.8
-2	lbs		1,095	*1,660	715	*1,205	530	*894	417	*826	400	10.2
-3	lbs		1,104	*1,430	717	*1,031	530	-	-	*826	459	9.2

# STANDARD EQUIPMENT

## ENGINE SYSTEM

- Dry type air cleaner (inside and outside elements)
- Manual mechanical accelerator
- Engine manual preheating
- Fuel tank with drain plug
- Fuel supply passage with electric fuel pump
- Fuel shutoff valve
- Fuel level sensor
- Fuel refilling and fuel level alert
- Fuel prefilter with water separation
- Fuel filter
- Radiator group with drain plug
- Coolant-level indicator (ground level)
- Cold start assembly (-15°C)

## ELECTRICAL SYSTEM

- Display: hour meter, tachometer and timer etc.
- Indicator: engine oil pressure, low fuel level, air filter plugging, overheating, high fuel level, etc.
- Horn
- Pilot cut-off switch
- Battery disconnect switch
- 12V battery
- Data diagnosis port
- Auto diagnosis system
- Maintenance free battery
- Working lights: 1 on boom, 1 on cabin
- Fuse box

## HYDRAULIC SYSTEM

- Pilot accumulator
- Hydraulic test port: main pump
- Blade cylinder guard
- Straight travel function
- Integrated shift lever with high speed and creep speed
- Dual way auxiliary lines, with multifunctional joystick control

## OPERATOR STATION

- Enclosed cabin with TOPS standard (ISO 12117) & ROPS (ISO 3471)
- General seat with 2' red retractable seat belt
- Joysticks with button control
- AM/FM Radio with MP3 audio jack, only for cabin
- Washable floor mat
- Opening front windshield
- Manual heater (for enclosed cab)
- Defroster
- Fresh air ventilation

## DIGGING EQUIPMENT

- Boom 1,685 mm (5'6")
- Boom swing
- Arm 1,070 mm (3'6")
- Counterweight 70 kg (154 lb)

## UNDERCARRIAGE

- Retractable undercarriage
- Rubber shoes 230 mm (9")
- Foldable dozer blade

# OPTIONAL EQUIPMENT

## ENGINE SYSTEM

- Auto-idle function

## ELECTRICAL

- Engine stop switch
- Travel alarm (alarm during machine travel)
- Rotating beacon (top cab mounted, for caution, switch in cab)
- Automatic idle system
- Working light, one on left side of canopy
- Working light, one on right side of cabin or canopy
- Working lights, on cab, front 4 and rear 2
- Seat belt connect with warning beacon, along with mechanical suspension seat, cabin
- GPS

## HYDRAULIC SYSTEM

- Auto-shift travel speed
- Load holding valve on boom cylinder
- Load holding valve on arm cylinder
- Load holding valve on dozer blade cylinder
- Quick coupler lines, high pressure, low flow
- Dual way auxiliary lines; attachment rotation lines, with proportional joystick control, with flow adjustment function
- Manual switch on auxiliary circuit: one way / dual way
- Travel pedal

## CAB

- Canopy
- Removable front cab guard (only for cabin)
- Lower-front guard screen (only for cabin)
- Mechanical suspension seat, 2-inch retractable belt
- Fire extinguisher
- Rear view mirror

## DIGGING EQUIPMENT

- 1,210 mm (4') long arm
- Additional bolt-on counterweight, weight adds 30 kg (66 lbs)

## UNDERCARRIAGE

- 230 mm (9") steel track
- Rubber crawler pads
- Long dozer blade (to reach the bucket)



**Guangxi LiuGong Machinery Co., Ltd.**

No. 1 Liutai Road, Liuzhou, Guangxi 545007, PR China  
T: +86 772 388 6124 E: overseas@liugong.com  
www.liugong.com

Like and follow us:



**LG-PB-9018F-Stage V-16-26022020-ENG**

The LiuGong series of logos herein, including but not limited to word marks, device marks, letter of alphabet marks and combination marks, as the registered trademarks of Guangxi LiuGong Group Co., Ltd. are used by Guangxi LiuGong Machinery Co., Ltd. with legal permission, and shall not be used without permission. Specifications and designs are subject to change without notice. Illustrations and pictures may include optional equipment and may not include all standard equipment. Equipment and options varies by regional availability.